

# MASSMAN ENGINEERING, LLC.

## FILTER-TECH DIVISION

### STREAMLINING PRODUCTION THROUGH AUTOMATION

#### Automated Cartridge Assembly Machine ACAM Series C - Metal Clip

We are experts at designing systems that help you increase production efficiency, improve production flexibility plus reduce manufacturing costs.

**What Massman customers say:**  
 "Thank you for the tremendous job your team did on our ACAM project. You were with us every step of the way from initial planning to final installation in our facility. Please let everyone know how much we appreciate your dedication to detail and the high standards of quality you built"



ACAM – SERIES C

#### 1. Filter Collation

Positions pleated block

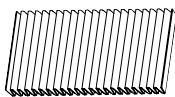

#### 2. Filter Forming

Forms into cylinder

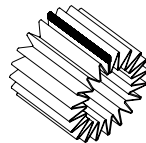

#### 3. Filter Joint Securing

Secures joint with metal clip

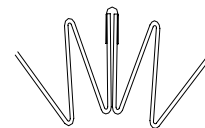

\*Clipped

#### 4. Center Tube Assembly

Inserts tube in pleat block

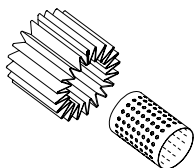

#### 5. Assembled Cartridge



\*Optional joint securing

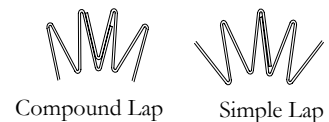

Compound Lap

Simple Lap

ACAM – Series C

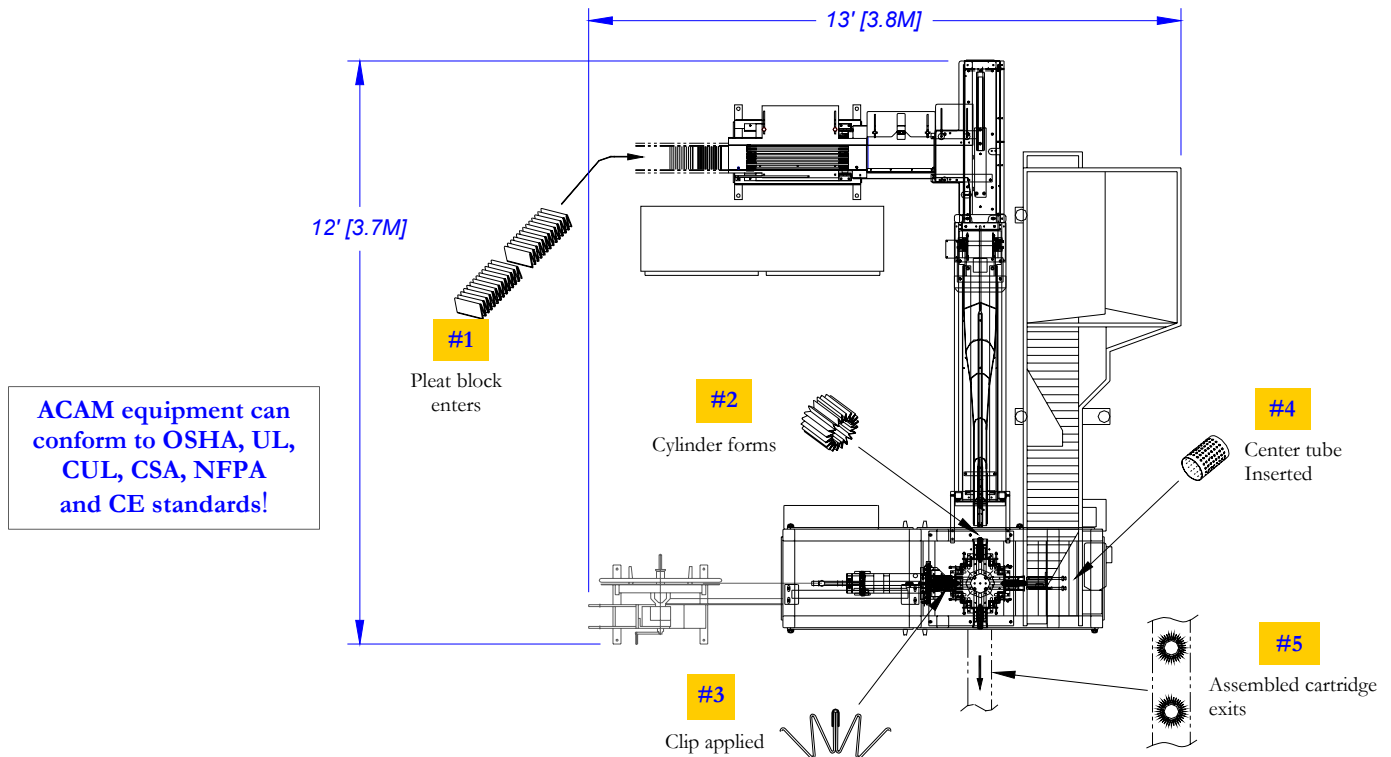

Product Specifications

Model	400C	600C	1000C
Type of Seam	Metal Clip	Metal Clip	Metal Clip
Throughput rate	50/min	45/min	25-38/min. (depends on products size)
Slit Width Range	1.25 – 4.00 inch 30-100 mm	1.60-6.00 inch 40-150 mm	2.0 – 10.0 inch 50-250 mm
Pleat Depth Range	0.375 – 0.750 inch 10-20 mm	0.500 – 0.938 inch 12 – 24 mm	0.500 – 1.500 inch 12-38 mm
Center Tube Diameter Range	1.0 – 1.3 inch 25 –32 mm	1.2 – 2.0 inch 30-50 mm	1.2 – 2.8 inch 30-70 mm

For more information, please contact:



651-739-1700 • fax 651-739-1777 • 7033 6th St. N. • St. Paul, MN 55128 USA  
[www.MassmanLLC.com](http://www.MassmanLLC.com) • [info@MassmanLLC.com](mailto:info@MassmanLLC.com)